



## Installation Instructions Fork Lowering Kit Harley Davidson 2014 FLH/FLT

### ATTENTION

Statements in these instructions that are preceded by the following words are of special significance:

#### **Warning**

This means there is the possibility of injury to yourself or others.

#### **Caution**

This means there is the possibility of damage to the vehicle.

#### **Note**

*Information of particular importance has been placed in italics.*

### Lifetime Limited Warranty

Progressive Suspension warrants to the original purchaser this Part to be free of manufacturing defects in materials and workmanship with a lifetime limited warranty. In the event warranty service is required, you must call Progressive Suspension immediately with a description of the problem.

If it is deemed necessary for Progressive Suspension to make an evaluation to determine whether the part is defective, a return authorization number will be given by Progressive Suspension. The parts must be packaged properly so as to not cause further damage and returned prepaid to Progressive Suspension with a copy of the original invoice of purchase and a detailed letter outlining the nature of the problem. If after the evaluation by Progressive Suspension the part was found to be defective it will be repaired or replaced at no cost to you. If we replace it, we may replace it with a reconditioned one of the same design.

Progressive Suspension shall not be held liable for any consequential or incidental damages resulting from the failure of a Progressive Suspension part. Progressive Suspension shall have no obligation if a part becomes defective as a result of improper installation or abuse.

#### **Warning**

Changing the chassis and/or suspension on any vehicle will change the handling characteristics of that vehicle. Care should be taken when operating the vehicle with such modifications while getting accustomed to the new handling characteristics.

### IMPORTANT NOTICE

**Caution:** Removing and replacing fork springs must be performed by a qualified mechanic or according to steps outlined in a professional workshop manual that relates to your particular make, model and year motorcycle.

The vehicle must be securely blocked to prevent it from dropping or tipping when the fork springs are removed. Failure to do so can cause serious damage and/or injury.

Progressive Suspension Fork Springs are designed to work with the OEM (Original Equipment) forks. Use of this product on any forks other than OEM may produce an unsatisfactory ride and void the warranty.

### Installation

- Read all the instructions carefully before installing this kit on your motorcycle. Use your factory authorized manual as a reference while installing this kit.
- Support and lift the motorcycle securely so the front wheel is off the ground. The balance point is toward the front of the engine.
- Remove forks according to instructions contained in your factory authorized shop manual.

#### **Note**

*For maximum performance we highly recommend that the forks be disassembled and thoroughly cleaned, inspected and new fork oil installed - we recommend a 20wt. fork oil. See fine tuning for more information. Fork oil level should be measured with the fork spring(s) removed and the fork completely compressed. The measurement from the top edge of the fork tube to the fluid level should be 140mm.*

- The Progressive Suspension fork spring kit is a direct replacement of your stock springs. You will use the supplied preload spacers (which you may have to cut to length).

#### **Caution**

While the installation of this fork lowering kit will not change the compressed length of the front forks, we have found that some bikes may not have adequate clearance between the fender, fairing and/or accessories. So we recommend with the fork springs removed from both forks, re-install the forks, fender, wheel and anything else you may have removed and lift the front forks, or lower the bike to completely compress the front forks. With the forks fully compressed, check for adequate clearance between the tire, fender, fairing, crash bar, accessories, etc. while turning left to right - lock to lock. You must correct any clearance issues prior to installing this kit to avoid vehicle damage and/or vehicle control problems.

## Installation (cont.)

- After removing both forks, start with one of the forks and remove the fork cap, then remove the fork spring.

### Warning

The fork cap is under spring pressure and care must be taken as it is removed to avoid injury! Keep downward pressure on the cap as you unscrew the final threads, this will minimize the spring "jump" that will occur as soon as the cap is fully un-threaded

### BE CAREFUL!

- Drain the fork oil, and then with the fork completely compressed remove the damper rod & top-out spring by removing the fork bolt (with crush-washer) in the bottom of the fork. Keep the fork assembly fully compressed at this point to keep the stock bottoming-cup properly located.
- In addition the stock top-out spring (on the damper-rod) install either ONE of the supplied top-out springs to lower your forks approximately 1" inch OR TWO of the supplied top-out springs to lower your forks approximately 2" inches - as illustrated on page 3.
- Drop the damper-rod along with the chosen number of top-out springs back into the fork. Put a drop of red thread-locking agent on the fork bolt that came out of the bottom of the fork and reinstall it (with crush-washer), tightening it back into the damper-rod. Torque the bolt to the factory recommended specification of 11-18 ft. lbs.
- Repeat the process on the other fork - putting the same number of top-out springs on the damper-rod.
- Preload spacer length - before going any further make sure you have the proper preload spacer lengths ready to install in your forks. If you are lowering your forks 1" inch then the included preload spacers should already be the correct length - 1.6"(41mm) - and are ready to use. However if you are lowering your forks 2" inches you will need to cut both of the supplied preload spacers to a length of 0.6" of an inch (15mm).
- Secure the fork assembly so you can fill it with fluid. This may require stroking the assembly to draw fluid from the inner fork tube in to the outer fork slider. Pour enough 20 wt. fork fluid in each fork, pausing to stroke the assembly to get the fluid into the outer fork slider, to achieve the recommended 140mm fork fluid level - which is measured from the top lip of the fork tube to the fluid, with the fork compressed all the way and the fork spring removed. Go slow pouring a little at a time then stroke the fork, failure to do this could cause the required amount of fluid to overflow and result in an inaccurate fluid level reading.

### Caution

**NEVER ADD TOO MUCH OR TOO LITTLE FLUID RESULTING IN A MEASUREMENT LESS THAN 140mm WHEN USING THIS SPRING KIT.**

- In each fork leg, install one of the supplied Progressive Suspension fork springs into the fork. Then install one of the stock washers followed by one of the supplied preload spacers (cut to recommended length), and finally the stock fork-cap (see illustrations on page 3).

- While reinstalling the fork cap be certain to torque it to the proper specification per a factory authorized manual. Reinstall fork, fender, wheel, and all other components per a factory authorized shop manual. Remove motorcycle from lift and re-check all fasteners for proper tightness per your factory authorized manual.
- The operator must use extreme caution when operating a modified motorcycle, particularly while getting familiar with its altered handling characteristics and ground clearance.
- Technical info: Our technical staff will assist you if you have any problems or questions. Call (714) 523-8700 from 8 am to 4 PM Pacific time.
- For totally balanced suspension, we highly recommend installing a pair of Progressive Suspension shocks, also available at your local dealer.

## FINE TUNING

- Fork Oil: Though we recommend using a 20wt. fork fluid, oil viscosity can be changed to alter damping. Heavier oil to increase damping. Lighter oil to decrease damping. Increase in 2.5 weight increments (i.e. from 2.5 weight to 5 weight.) Oil viscosity will have more effect on rebound damping than compression damping, too high a viscosity can create harshness on sharp edge bumps.



# Illustrations

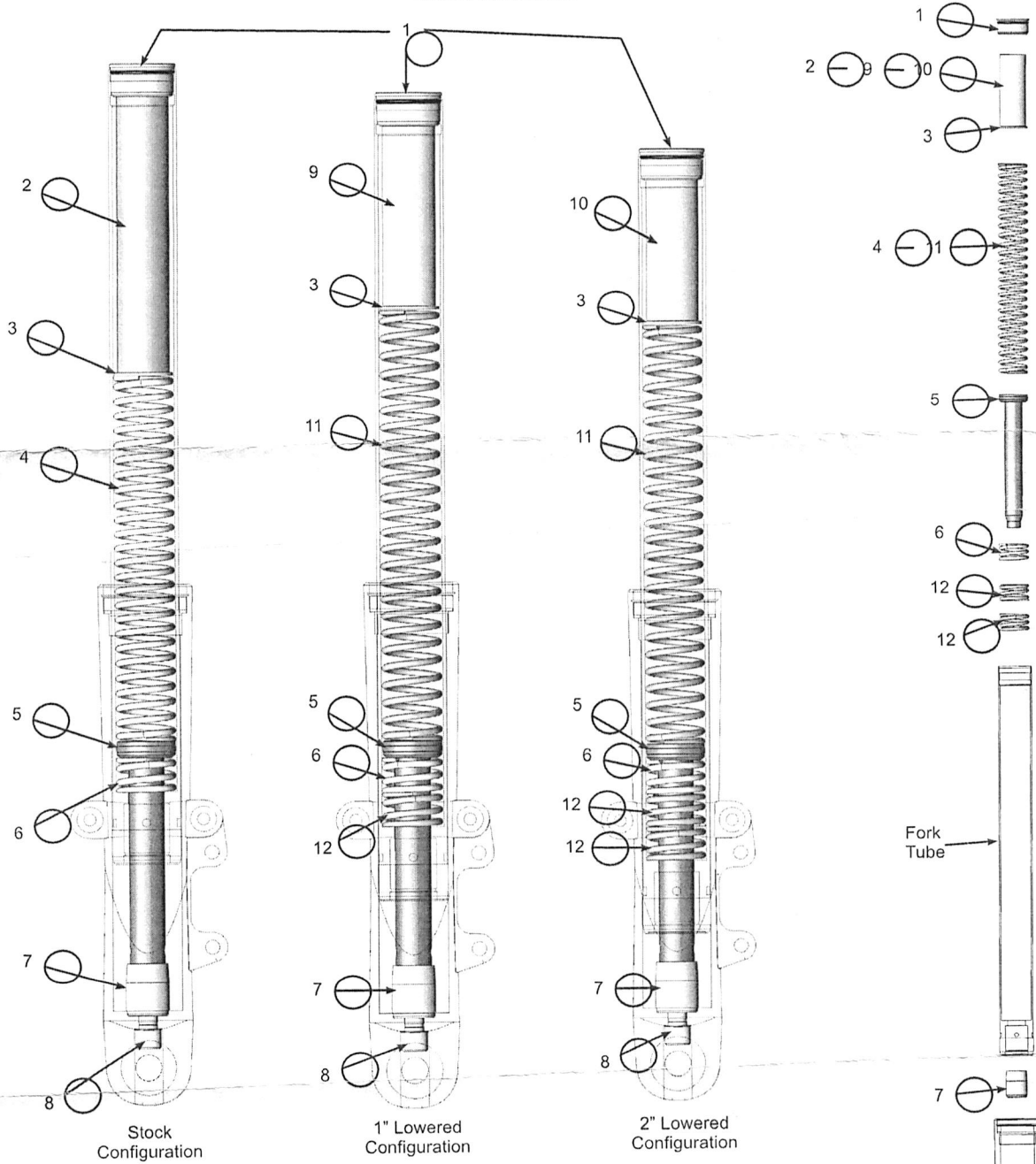

(Illustration NOT to scale)

- |                                    |  |
|------------------------------------|--|
| 1. Fork Cap                        | 7. Bottom-cup                            |
| 2. Stock Preload Spacer (replaced) | 8. Fork Bolt with Crush-wahser           |
| 3. Stock Washer                    | 9. Supplied Preload Spacer (un-cut 1.6") |
| 4. Stock Spring (replaced)         | 10. Supplied Preload Spacer (cut 0.6")   |
| 5. Damper-rod                      | 11. Progressive Suspension fork spring   |
| 6. Stock Top-out Spring            | 12. Supplied Top-out Spring              |



Fork Tube

Fork Slider

8