



A Division of Thiessen Products, Inc.

## INSTRUCTION SHEET FOR TOOL #788

### EXHAUST SEAL INSTALLER TOOL

This tool installs the exhaust pipe seal H-D No. **65324-83B** or Screamin' Eagle No. **17048-98** Performance Exhaust Seal kit, or equivalent into Evo Big Twin, XL, or Twin Cam models. It will position the seal evenly into the head exhaust port thus preventing any exhaust leaks.

No. **788** Use on all 1984 to present Evo Big Twin, XL, and Twin Cam models.

#### Installation:

1. Position exhaust seal on tool. Note that the tool has a step locator to correctly position the type of seal used. The tool side with the small step is for locating the H-D No. **65324-83B** seal.

**Note:** *The thinnest edge faces tool plate. The other side of the plate is for the usage of No. **17048-98** seal kit. See Fig 1.*

2. This tool can install the seals two different ways as shown in. **See Fig. 2 and Fig 3.**

**Option 1 :** After your new seal is in position on tool plate you can use the two exhaust flanged nuts H-D No. **7593** to install the tool to the head. Alternate threading on the nuts onto the exhaust mounting studs until tool bottoms out on the head. Then install the pipes up to the head per H-D service manual. **See Fig 2.**

**Option 2 :** Using tool handle JIMS No. **33416-80** ( order separately, not included with No. **788** tool ) install small end into the center hole of No. **788** plate with a new seal in position. Place these pieces up to the head and onto the exhaust mounting studs. Then use a mallet to lightly tap on end of handle until tool plate seats in the head. Then install the pipes up to the head per H-D service manual. **See Fig 3.**

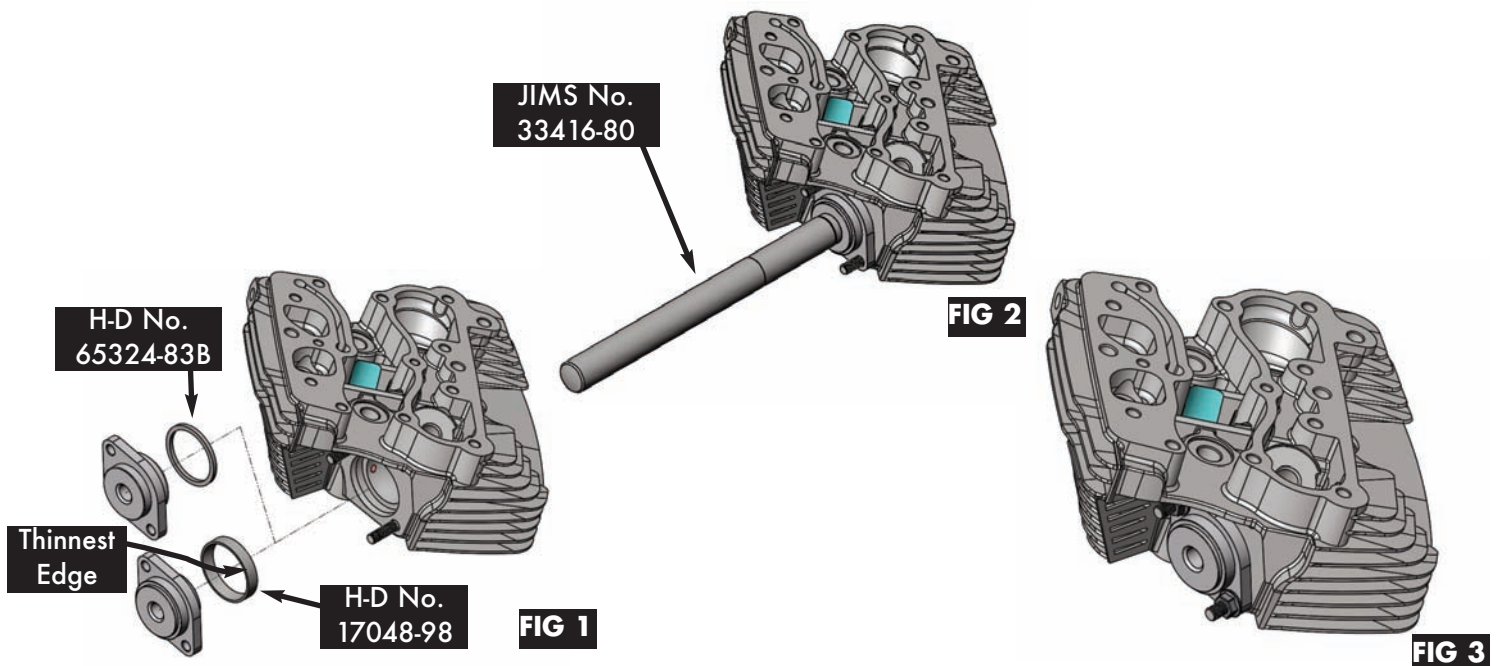

*Performance Parts For Harley-Davidson Motorcycles*